



# VCMH

- ▶ **Constant volume**
- ▶ **Mechanical**
- ▶ **Adjustable within it's volume range**

## Design:

Housing and damper: galvanized sheet steel.

Damper shaft: stainless steel  
Bearings are maintenance free.

### Optional:

rubber sealing rings on connecting spigots.

## Available types:

**V C M H - -**

**V** volume unit  
**C** constant volume  
**M** mechanical control  
**H** round design, adjustable

### - adjustability

**O** manual  
**M** actuator

### - connection

**O** standard (no rubber seals)  
**R** rubber seal  
**D** double walled  
**A** rubber seal and double walled

## Application:

The VCMH is a mechanical constant volume damper. The damper is designed to maintain the design volume independent of inlet pressure. The design volume ( $m^3/h$ ) is easily set by adjustment of the external sliding scale. The operating range of the damper is 50 - 1000 Pa ( $\pm 5\%$ ). The volume flow rate is maintained constant at varying pressures within the specified pressure range, with an approximate deviation of between  $\pm 5\%$  and  $\pm 10\%$ . Smaller models and/or small air duties may result in an increasing deviation.

## Features:

Seven model sizes available. Volume range: 0.014 - 0.611  $m^3/s$  nominal (50 - 2200  $m^3/h$ ).  
Low pressure drop.  
Low response pressure.  
Horizontal, vertical or angle mounting position.  
Each unit can be fully adjusted on site within its operating limits.

## Mounting:

Constant volume valve type VCMH are insensitive to mounting position. Consideration should be given to the disruption of the air flow through bends and junctions. Three times the diameter straight before the unit is recommended and 2 times the diameter after the unit. Duct dimensions in this connection according to the size of the unit.

### Authority:

To ensure accuracy of the unit, the pressure drop across the damper should be at least equal to the total pressure drop behind the unit (duct plus grilles, diffusers).

### General:

The VCMH can not be set to a closed position.

## Dimensional data:

model	A	L <sub>1</sub>	L <sub>2</sub>	D
80	40	242	322	79
100	40	242	322	99
125	40	242	322	124
160	40	242	322	159
200	40	272	352	199
250	60	292	412	249
315	60	342	462	314

## Remark:

The stated dimensions are nominal sizes in mm.  
Connection "D" = is actual O.D.  
Secondary attenuators if required are available upon request.

## Dimensions:

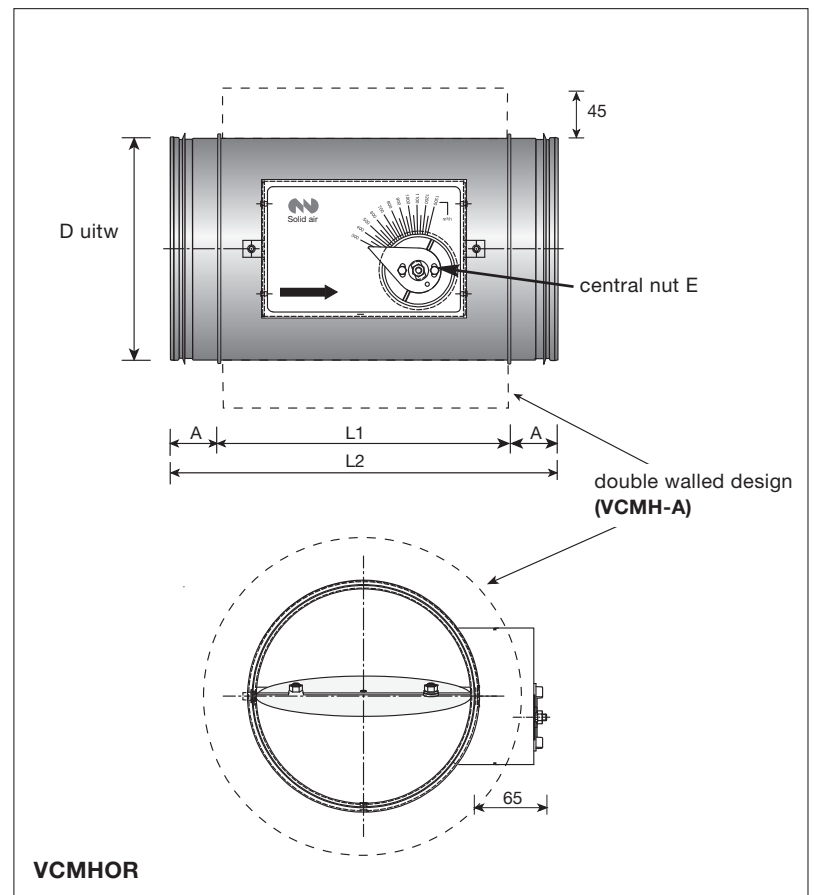

## Discharge sound VCMH:

model	air volume				static inlet pressure																				
					50 Pa						100 Pa						250 Pa								
					Lw in octave			Lp			Lw in octave			Lp			Lw in octave			Lp					
m³/s	m³/h	P <sub>min</sub>	m/s	63	125	250	500	1k	2k	Lp	63	125	250	500	1k	2k	Lp	63	125	250	500	1k	2k	Lp	
80	0.014	50	50	2.8	40	38	31	32	32	31	12	46	42	36	37	37	36	17	47	43	38	38	39	40	18
	0.022	80	50	4.4	43	39	35	34	36	35	14	48	45	41	38	39	38	20	48	46	44	43	44	45	22
	0.031	110	50	6.1	42	38	36	36	38	36	14	48	43	40	40	41	40	19	49	48	47	45	47	47	24
	0.042	150	50	8.3	43	41	39	41	39	39	17	48	47	45	44	45	44	23	51	51	49	49	49	49	27
	0.056	200	70	11.1	-	-	-	-	-	-	-	51	50	49	49	47	46	26	54	54	55	53	52	52	31
100	0.019	70	50	2.5	25	29	22	23	23	24	-	36	40	33	33	34	35	13	46	42	37	38	39	40	17
	0.036	130	50	4.6	41	38	34	32	35	34	13	45	44	39	39	38	37	18	50	49	44	46	46	46	24
	0.053	190	50	6.7	45	41	38	38	40	38	17	46	46	43	41	41	41	21	51	50	48	48	47	49	26
	0.069	250	50	8.8	45	44	42	43	41	43	20	50	49	48	47	48	46	25	53	54	53	52	51	50	30
	0.083	300	70	10.6	-	-	-	-	-	-	-	52	54	51	51	50	48	29	57	58	55	55	55	55	33
125	0.033	120	50	2.7	43	41	34	33	35	33	15	48	44	38	38	41	39	19	51	50	43	43	45	46	24
	0.056	200	50	4.5	45	42	37	37	39	36	17	48	46	41	40	41	40	21	55	51	48	48	50	49	27
	0.078	280	50	6.3	47	44	39	41	40	39	19	50	49	46	45	46	45	24	54	54	50	51	51	53	29
	0.100	360	50	8.1	48	44	42	43	42	41	20	52	51	49	48	47	47	27	56	57	56	55	54	54	33
	0.139	500	70	11.3	-	-	-	-	-	-	-	55	55	53	54	51	50	31	59	60	59	59	58	60	36
160	0.042	150	50	2.1	46	43	36	35	37	35	17	50	47	40	41	43	41	21	53	52	46	45	46	48	26
	0.083	300	50	4.1	47	43	39	39	39	38	18	52	49	45	44	44	43	24	54	52	49	49	49	51	27
	0.125	450	50	6.2	46	44	41	41	43	40	19	54	51	46	47	49	46	26	58	58	53	55	54	55	33
	0.167	600	50	8.3	48	46	44	45	44	43	22	54	53	51	51	50	50	28	59	58	57	58	56	57	34
	0.222	800	70	11.1	-	-	-	-	-	-	-	56	56	55	57	54	52	33	61	64	63	63	60	60	40
200	0.069	250	50	2.2	45	42	36	36	38	36	17	50	46	40	42	43	40	21	55	53	48	49	50	50	28
	0.125	450	50	4.0	45	42	38	38	39	37	17	51	48	44	43	45	44	23	56	54	50	51	51	52	29
	0.194	700	50	6.2	45	43	40	42	40	39	19	51	49	46	48	48	46	25	58	57	55	55	55	56	33
	0.250	900	50	8.0	49	47	45	46	44	44	23	54	52	52	52	51	50	29	58	59	58	58	56	57	35
	0.333	1200	80	10.6	-	-	-	-	-	-	-	55	54	53	54	52	50	30	61	64	61	63	60	60	39
250	0.111	400	50	2.3	48	43	37	38	39	37	18	52	48	42	44	43	44	23	55	52	48	47	49	50	27
	0.194	700	50	4.0	47	44	41	38	39	38	19	53	51	46	45	46	45	26	59	56	51	51	52	53	31
	0.306	1100	50	6.2	48	45	44	42	42	42	21	53	51	48	49	48	47	27	59	57	54	56	54	55	33
	0.389	1400	50	7.9	48	46	44	44	43	42	22	55	54	52	53	51	49	30	58	60	59	57	56	58	36
	0.556	2000	90	11.3	-	-	-	-	-	-	-	57	56	55	57	55	53	33	63	65	62	64	62	61	40
315	0.167	600	50	2.1	44	42	35	35	36	35	16	52	50	42	43	44	43	24	56	53	50	48	51	52	28
	0.306	1100	50	3.9	47	44	41	39	39	39	19	55	52	47	47	47	46	27	60	56	53	53	53	54	32
	0.472	1700	50	6.1	48	45	43	42	42	41	21	54	53	51	49	50	48	28	59	58	56	56	55	56	34
	0.611	2200	50	7.8	50	49	46	46	46	44	24	56	55	52	52	52	50	30	60	61	60	59	59	59	37
	0.833	3000	90	10.7	-	-	-	-	-	-	-	61	60	58	59	56	55	36	63	64	64	63	63	62	41

### General:

- Minimum static pressure drop over the control P<sub>min</sub> in Pa
- Sound power L<sub>w</sub> in dB in the octave bands at a reference value of 10<sup>-12</sup> Watt.
- The selection table shows the Lw and Lp values for discharge sound. The sound pressure levels Lp, dB(A) stated have taken into account the attenuation of a silencer and a ceiling diffuser with plenumbox, as table 2
- For radiated sound data use table 1
- The adopted room attenuation is 10dB. If the actual value is lower, the dB(A) values have to be corrected.
- Note: the Lw values have been measured with one end nozzle of the duct in the free room. (i.e. including end reflection). For rooms with a low sound level (<25dB(A)), hard surfaces, light walls etc. consult an acoustic consultant.
- The available pressure drop across the unit has to be minimal 50 Pa.

Interpolation of intermediate values is acceptable.

### Table 1 Correction radiated sound:

model	80	100	125	160	200	250	315
VCMH-O/R single walled	-18	-17	-17	-15	-14	-13	-12
VCMH-D/A double walled	-36	-35	-35	-33	-32	-31	-30

### Table 2 octave band correction :

	octave bands					
	63	125	250	500	1k	2k
discharge sound	0	5	10	20	30	30