

Remote control 0...100%

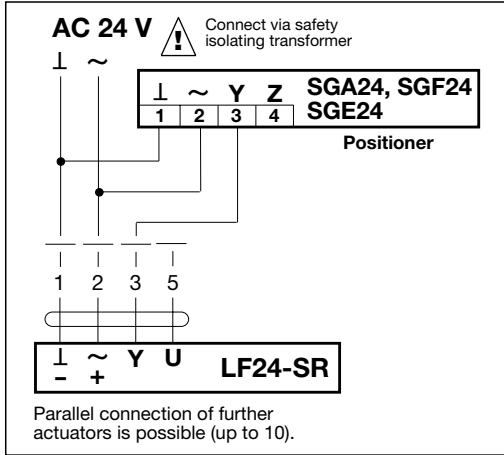

Minimum position

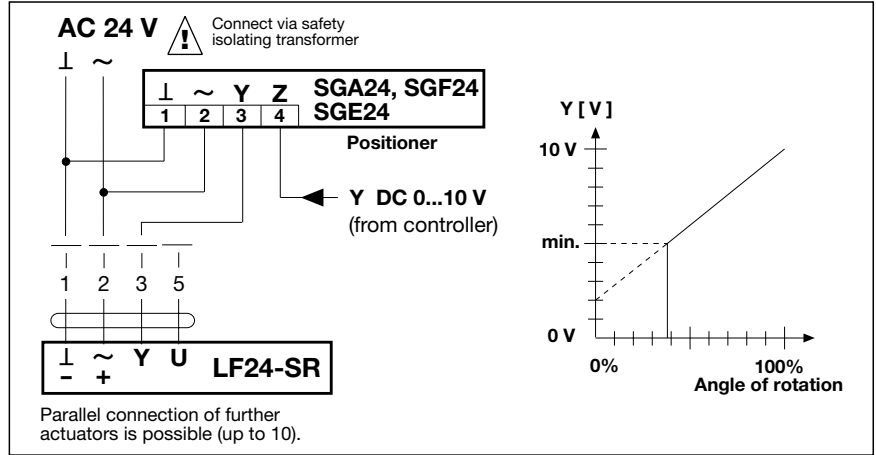

w0116712

Override control

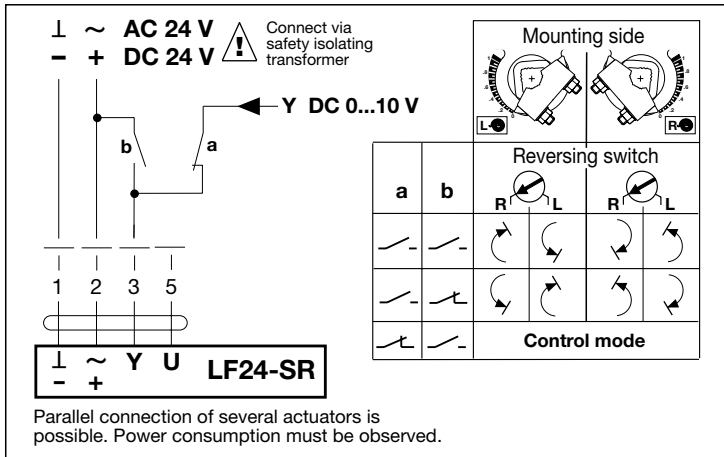

Control by 4...20 mA via external resistor

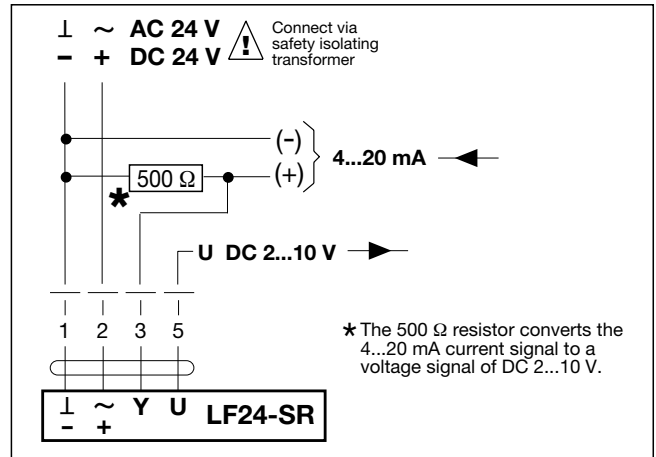

Position indication and / or master-slave control (depending on position)

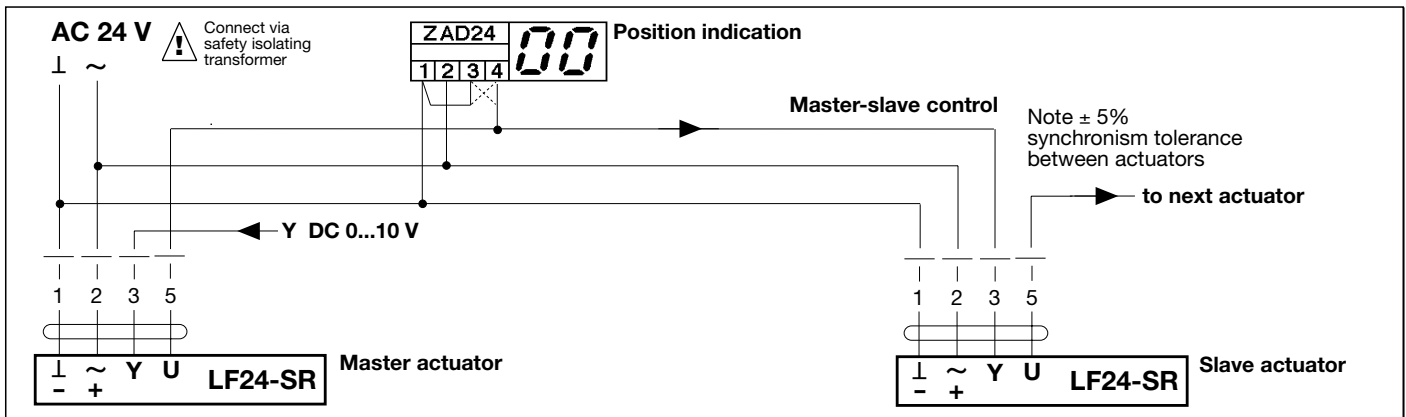

Function monitoring

