

FIRE DAMPER



EI 120 (v, h, i→o)S 500Pa

PN EN 13501-3+A1 : 2012

EN 15650 : 2010

EC Certificate of Conformity:

CE 1488-CPD-0280/W

Damper tightness class: 4

Casing tightness class: C

EN-1751:2002

in libraries of
 **Fluid Desk**
 Building Engineering Solutions

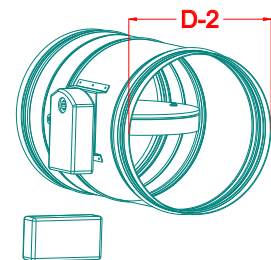

FIRE SAFETY

FUNCTION

The CX-5 fire damper is designed for buildings outfitted with a one-stage evacuation scenario based on the fire-affected zone separation principle. The damper meets the requirements for buildings where in the event of a fire the affected zone should be isolated from the other zones by remotely closed fire dampers, while the ventilation system should operate normally in other zones.

APPLICATION

The CX-5 fire damper is used in ventilation or air conditioning ducts passing through fire resistant partitions. It allows separation of the affected zone in the event of a fire. After closing, the fire damper preserves resistance of the fire partition. In this way it protects other zones against smoke and fumes, and allows normal operation of the rest of the ventilation or air conditioning system.

At normal ambient temperatures the fire damper remains open (in the stand-by position). In the event of a fire the CX-5 blade closes and separates the fire zone (the damper blade moves to the safety position). Closure of the fire damper:

is activated automatically by the release of the fusible link when the air temperature in the duct rises above 72°C, or

is activated remotely by a control signal from the fire detection unit.

The fire damper is closed by a return spring mechanism. The closing mechanism is additionally fitted with a manual hand release, enabling manual checking of closing performance. Re-opening of the damper (returning it to the stand-by position in the event it has been remotely closed) is done manually by tensioning the spring with a spanner (size 13) or remotely by an actuator. In the event that the fire damper was automatically closed by the fusible link release, the fusible link must first be replaced with a new one and then the previously described actions should be performed to open the damper.

Fire damper can only be re-opened if the release mechanism is intact, otherwise it must be replaced. After the fire damper has been exposed to fire it must be replaced. Fire damper blade position monitoring is provided by electrical micro-switches.

DESCRIPTION

The CX-5 fire damper consists of:

- round casing made of galvanized steel sheet,
- movable damper blade made of fire resistant board,
- fire and smoke proof damper blade seals,
- control mechanism.

distributed by



43B Ghencea Blvd.
 Ghencea Business Center, 4th floor
 Bucharest 6, ROMANIA
 tehnic@rpgtechnology.ro
 www.rpgtechnology.ro

SELECTION AND DIMENSION

HYDRAULIC AND ACOUSTIC CHARACTERISTICS

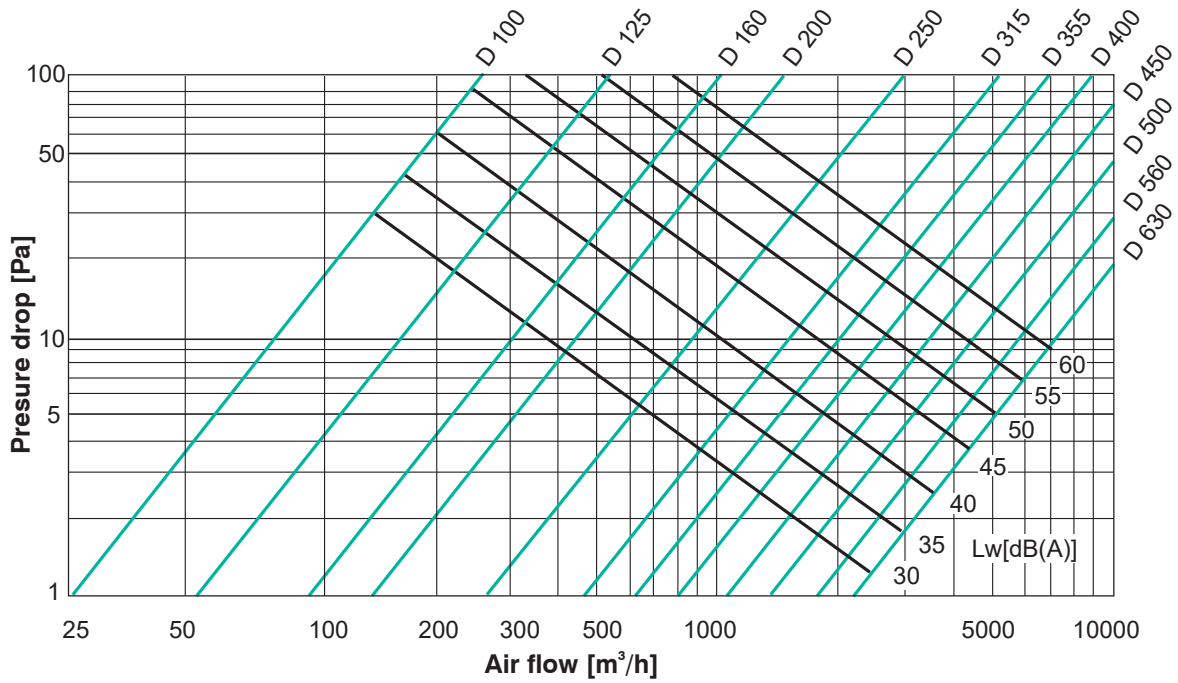

DIMENSION

Table of dimensions for brick/concrete partition wall G=110 mm (P) and light-weight partition wall G=125 mm (P*)

D [mm]	P [mm]	P* [mm]	B [mm]	Weight [kg]	S [dm ²]
100	350	380	-	5	0,48
125	350	380	-	6	0,83
160	350	380	-	7	1,50
200	390	420	-	7	2,15
250	450	450	-	8	3,67
315	450	450	9	9	6,23
355	450	450	28	10	8,13
400	450	450	51	11	10,58
450	450	450	75	13	12,67
500	450	450	100	15	17,15
560	450	450	130	17	21,84
630	450	450	165	19	28,04

It is possible to order a damper with a non-standard casing length from the range:

$$P_{\text{standard}} < P_{\text{required}} < 1040 \text{ mm}$$

GRYFIT CX-5 D100-D160

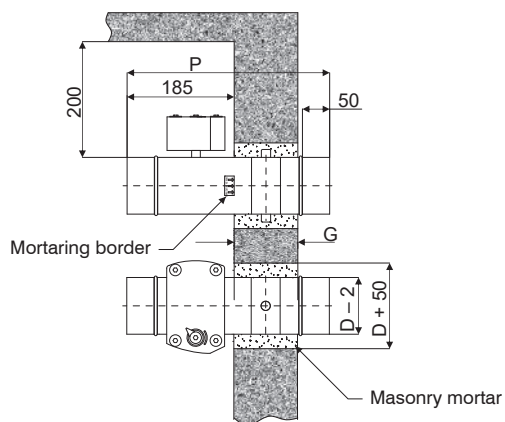

GRYFIT CX-5 D200

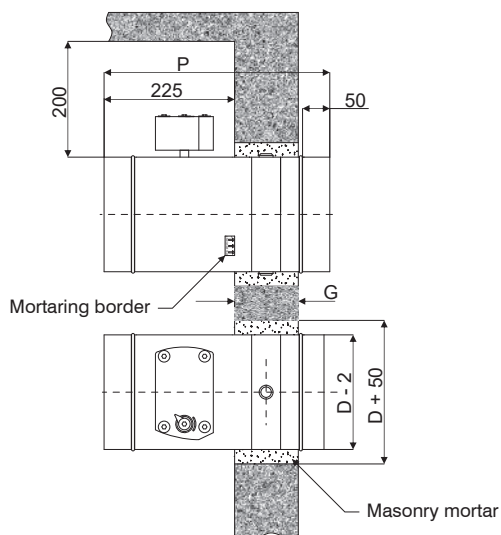

GRYFIT CX-5 D250-D630

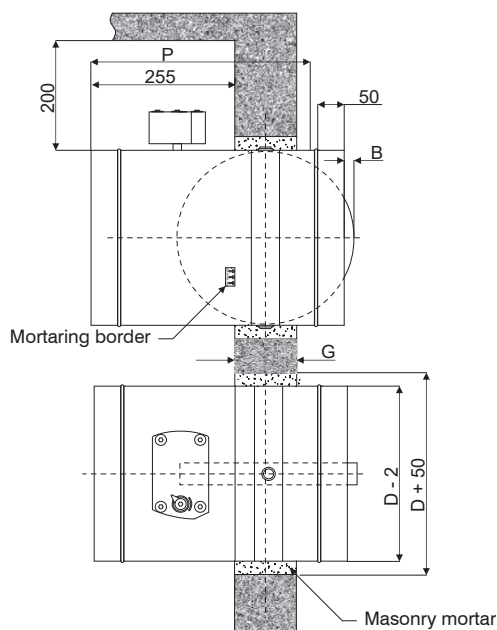

DIMENSIONS AND INSTALLATION METHOD

DAMPER INSTALATION IN A BRICK OR A CONCRATE WALL

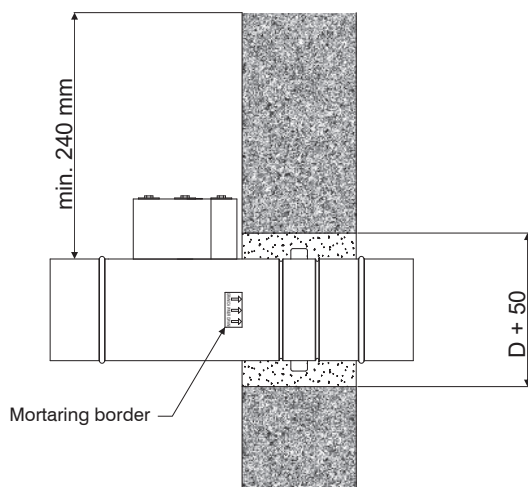

Minimum installation opening:
 $D_r = D + 50 \text{ mm}$

Mortaring border:
 is clearly marked by the label on the casing, damper blade should align with the center line of the partition wall's thickness (for construction elements of 110 mm thickness), if mortaring in wall the „mortaring border“ marking on the fire damper must be strictly observed

The GRYFIT CX-5 fire damper can be installed with its blade axis positioned horizontally as well as vertically.

DAMPER INSTALATION IN A LIGHT - WEIGHT PARTITION WALL

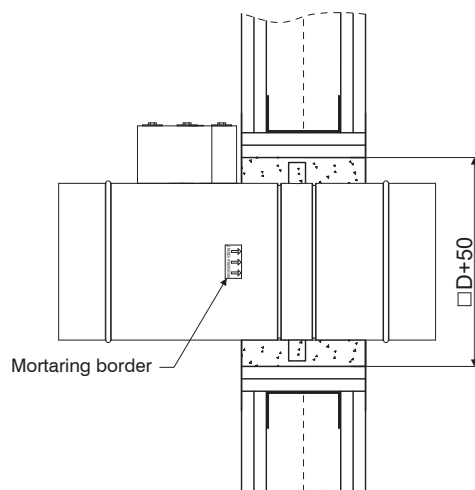

Minimum installation opening:
 $D_r = D + 50 \text{ mm}$

Mortaring border:
 is clearly marked by the label on the casing, damper blade should align with the center line of the partition wall's thickness (for construction elements of 125 mm thickness), if mortaring in wall the „mortaring border“ marking on the fire damper must be strictly observed

The GRYFIT CX-5 fire damper can be installed with its blade axis positioned horizontally as well as vertically.

DAMPER INSTALATION IN PARTITION HORIZONTAL

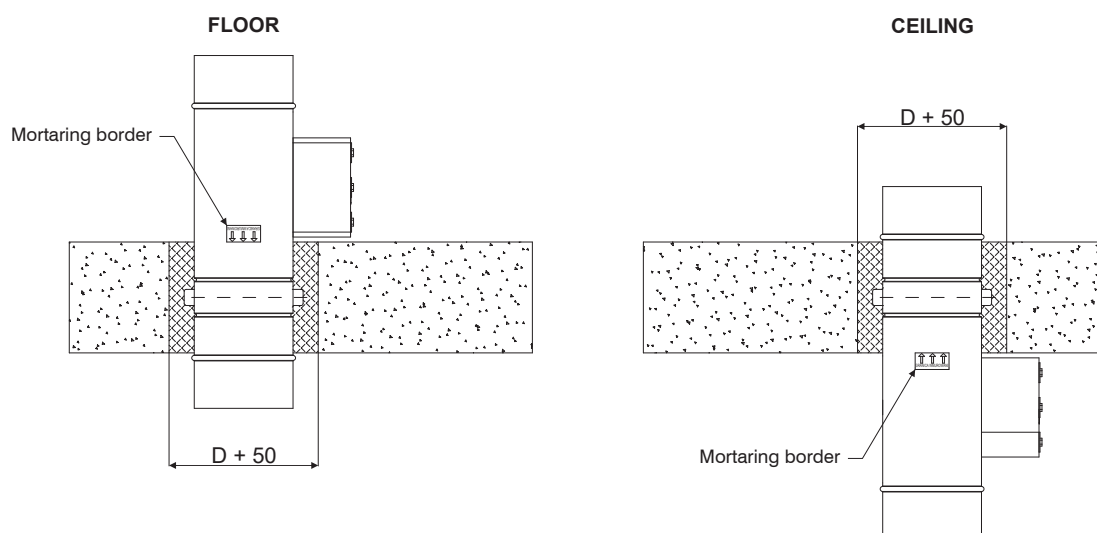

ACCESSORIES

ACCESSORIES FIR DAMPER CX+5 (EIS120)

1. Fusable link:

fussible link WT72C

2. Actuator:

ACTUATOR CHARACTERISTICS		
Actuator type	FDG-WT-8-24	FDG-WT-8-230
Supply voltage	24V AC/DC	230V AC
Power input during tensioning the spring	3,5W	9,2VA
Power input during stand-by	0,5W	6,9VA
Time of movement – engine	55-71s	55-71s
Time of movement – spring	21s	21s
Torque motor	8Nm	8Nm
Protection class	IP54	IP54
Sound power level – actuator	47dB(A)	47dB(A)
Sound power level – spring	52dB(A)	52dB(A)

3. EMS Module

Easy Maintenance System module guarantee quick and correct connection of the portable TZ tester that enables delivery of suitable control – impulse or deenergizing of a selected voltage – 24 V or 230 V, in purpose of functionality assessment during the installation work, commissioning process of the installation and during normal management of the building. Use of the EMS system together with the TZ tester speeds up commissioning of the installation considerably and leaves no doubt as regards to its correct performance.



Electrical wiring diagrams for FDG-WT-8 actuators

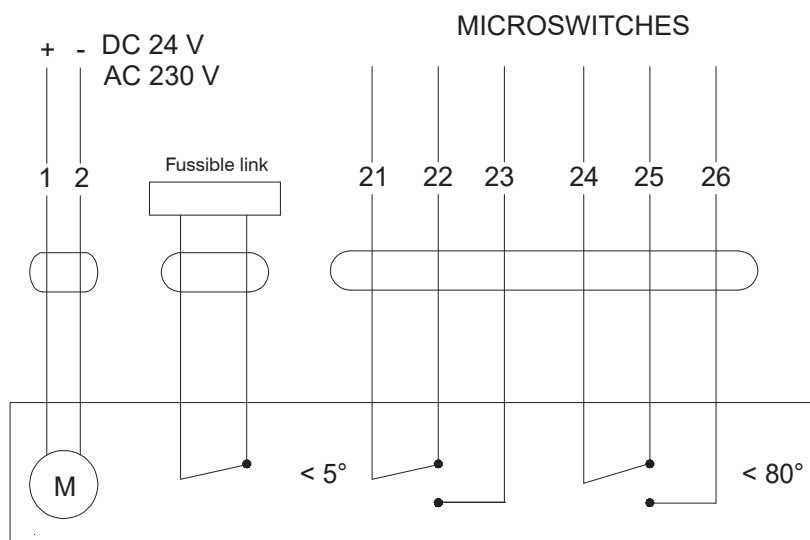

Electrical wiring diagrams for FDG-WT-8 actuators with EMS module

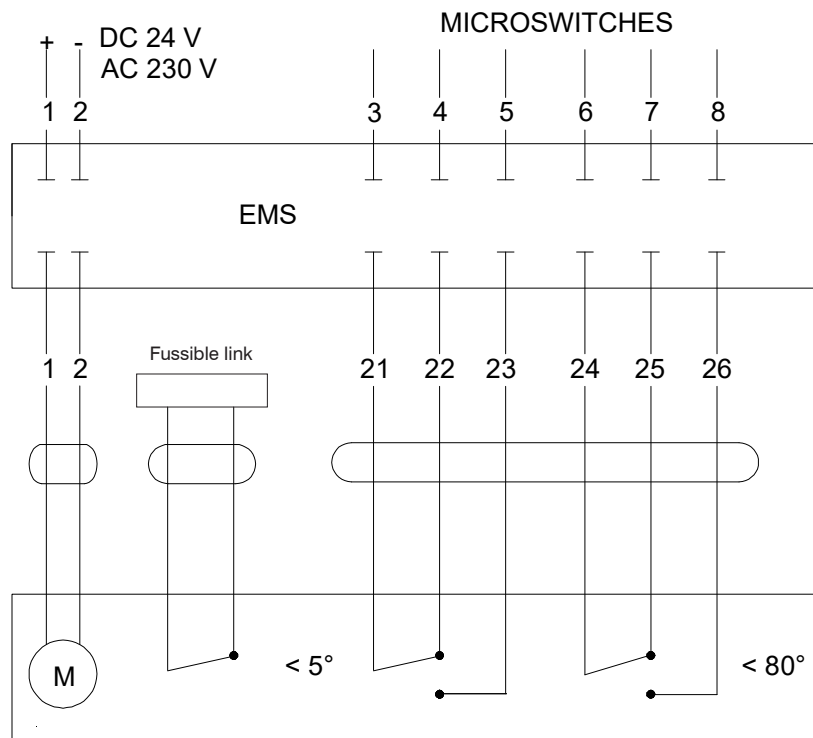

EXAMPLE OF SPECIFICATION AND PURCHASE ORDER

Enquiry:

Fire damper EIS120 GRYFIT CX-5, D=400 + Actuator 24/48V AC/DC FDG-WT-8-24+ Module EMS + EPDM gaskets

GRYFIT quotation:

GRYFIT CX-5, D=400 + FDG-WT-8-24 + EMS + EPDM gaskets T

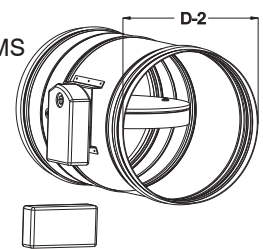

Enquiry:

Fire damper EIS120 GRYFIT CX-5, D=400 + Compact microswitches indicating open and closed position + EPDM gaskets

GRYFIT quotation:

GRYFIT CX-5, D=400 + 1WKKP + EPDM gaskets T

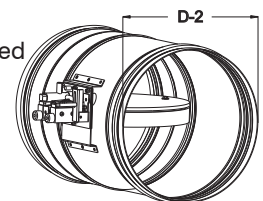

Design changes reserved. All rights reserved. GRYFIT air handling intelligence - GRYFIT - CX-5 - 11.13 - ENG